



FEATURES

- 2:1 Wide Range Voltage Input
- Continuous Short Circuit Protection with Current Foldback
- Operating Temperature Range -40°C to 85°C
- 0.2% Typical Load Regulation
- 1kVDC Isolation
- Efficiency from 81%
- 24V & 48V Nominal Input
- ±12V & ±15V Dual Outputs
- Power Density 0.94W/cm³
- Remote On/Off
- UL 94V-0 Package Materials
- No Electrolytic Capacitors
- Low Noise
- Custom Solutions Available

DESCRIPTION

The NDX series of DC/DC converters provide up to 7.5W of output power with dual outputs. Unbalanced loading capability with an optional input control pin which will shutdown the NDX from TTL levels. Input voltages of 24V (18V to 36V) and 48V (36V to 75V) with outputs of ±12V or ±15V are provided. The device is housed in a 5 sided metal case potted with UL 94V-0 rated material. The pinout is an industry standard 5 pin arrangement with an additional optional control pin.

SELECTION GUIDE¹

Order Code ²	Input Voltage V (nom.)	Output Voltage V	Output Current		Input Current			Efficiency (min) %	Isolation Capacitance pF
			±12.5% Load	±50% Load	0% Load	100% Load	Shut Down		
			mA	mA	mA	mA	mA		
NDXD2412	24	±12	±78.1	±312	6.3	380	0.4	81	56
NDXD2415	24	±15	±62.5	±250	7.0	380	0.4	82	56
NDXD4812	48	±12	±78.1	±312	5.9	190	0.5	82	57
NDXD4815	48	±15	±62.5	±250	5.9	190	0.5	82	58

INPUT CHARACTERISTICS¹

Parameter	Conditions	Min.	Nom.	Max.	Units
Voltage range	24V input types	18	24	36	VDC
	48V input types	36	48	75	
Reflected ripple current	24V input types with 10µF at input		260		mA p-p
	48V input types with 10µF at input		130		

OUTPUT CHARACTERISTICS¹

Parameter	Conditions	Min.	Nom.	Max.	Units
Rated Power				7.5	W
Voltage Set Point Accuracy	With external input/output capacitors		±2	±5	%
Line regulation	Low line to high line. With external input/output capacitors		0.04	0.4	%
Load regulation	25% total load to 100% total load With external input/output capacitors		0.2	0.75	%
Ripple	BW=20Hz to 300kHz With external input/output capacitors		5.0	10	mV rms
Noise	BW=DC to 60MHz With external input/output capacitors		50	150	mVp-p
Cross Regulation	% voltage change on negative output when positive load varies from 12.5% to 50% with negative load fixed at 50%		2.5	5	%

ISOLATION CHARACTERISTICS²

Parameter	Conditions	Min.	Nom.	Max.	Units
Isolation test voltage	Flash tested for 1 second	1000			VDC
Resistance	Viso = 1kVDC	1			GΩ

ABSOLUTE MAXIMUM RATINGS

Short-circuit protection (MAX case temperature rise 90°C above ambient)	Continuous
Internal power dissipation	2.3W
Lead temperature 1.0mm from case for 10 seconds (to JEDEC JESD22-B106 ISS C)	260°C
Minimum output load for specification	12.5% of rated load on each output
Control pin input voltage	7V
Input voltage, NDXD24 types	40V
Input voltage, NDXD48 types	80V

1. Specifications typical at T_a=25°C, with recommended input/output capacitors (refer to application note), nominal input voltage and rated output current unless otherwise specified.

2. If optional CTRL pin is required (as indicated in the mechanical dimensions section) suffix the part number with an 'E' when ordering e.g. NDXD2412E.

GENERAL CHARACTERISTICS ¹					
Parameter	Conditions	Min.	Nom.	Max.	Units
Switching Frequency	100% total load to 25% total load	100		620	kHz
Package Weight			20		g
Control Pin Input Voltage	Module ON (or pin unconnected)	-0.6		0.8	V
		-0.1		0.2	mA
	Module OFF	3.0		7.0	V
		0.3		3.0	mA

TEMPERATURE CHARACTERISTICS					
Parameter	Conditions	Min.	Nom.	Max.	Units
Operation		-40		85	°C
Storage		-50		130	
Case Temperature Rise	100% Load, Nom V_{IN} , Still Air		35		

MEAN TIME TO FAILURE (MTTF) ³				
Part Number	0°C	25°C	Units	
NDXD2412	2590	1528	kHrs	
NDXD2415	2492	1462		
NDXD4812	2587	1558		
NDXD4815	2351	1379		

APPLICATION NOTES

External Capacitance

Although these converters will work without external capacitors, they are necessary in order to guarantee the full parametric performance over the full line and load range. All parts have been tested and characterised using the following values and test circuit.

Value	
C_{IN}	C_{OUT}
10µF, 200V	100µF, 25V

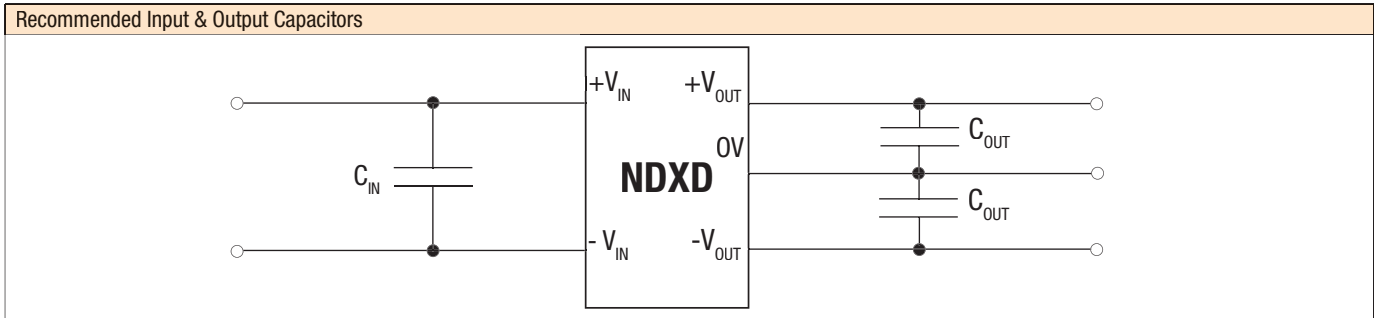

Control Pin

This provides an OFF function, which puts the converter into a low power mode. When the pin is high the converter is OFF. Standard TTL levels can be used but the maximum high level must not exceed 7.0V. The pin can be left open for normal operation or a voltage below 0.8V with respect to the $-V_{IN}$ pin.

Cross Regulation

Load regulation is at its best when the positive and negative loads are balanced. When the loads are asymmetric, the negative output is not as tightly regulated as the positive output. To meet ripple specification a total minimum load of 25% full load is required, however, the NDX can be used with much lighter loading at the expense of increased ripple. A small load is required on the negative output of 150mW to ensure the maximum negative output voltage is not exceeded.

Cross regulation is defined as change in the negative output voltage as a percentage of nominal as the positive output load is changed from 12.5% to 50%. The negative load is fixed at 50% of full load.

1. Specifications typical at $T_a=25^\circ\text{C}$, nominal input voltage and rated output current unless otherwise specified.
 2. All data taken at $T_a=25^\circ\text{C}$
 3. Calculated using MIL-HDBK-217F with nominal input voltage at full load.

PACKAGE SPECIFICATIONS

MECHANICAL DIMENSIONS

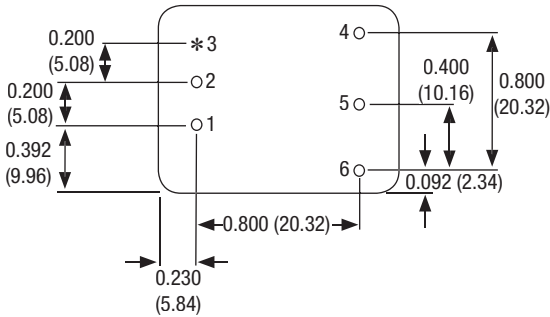
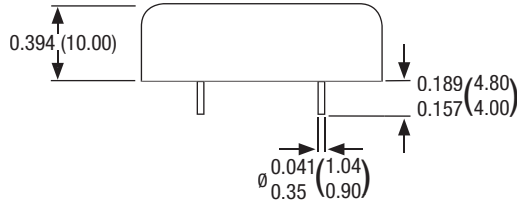
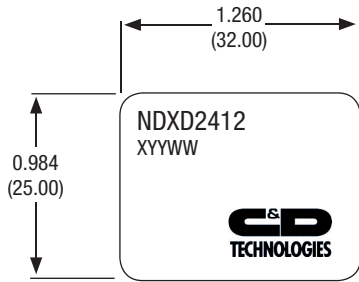

* Optional pin
Unless otherwise stated all dimensions in inches (mm) ± 0.010" (0.25mm). All pins on a 0.100 (2.54) pitch and within 0.010 (0.25) of true position.

PIN CONNECTIONS

Pin	Function
1	-V _{IN}
2	+V _{IN}
3*	CTRL
4	+V _{OUT}
5	OV
6	-V _{OUT}

Package weight: 20g

RECOMMENDED FOOTPRINT DETAILS

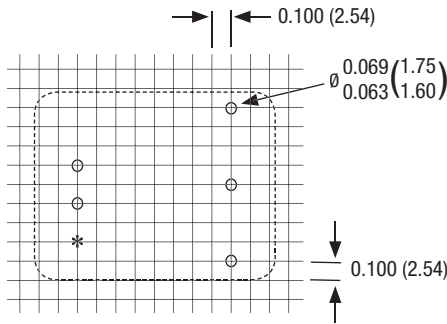

TUBE OUTLINE DIMENSIONS

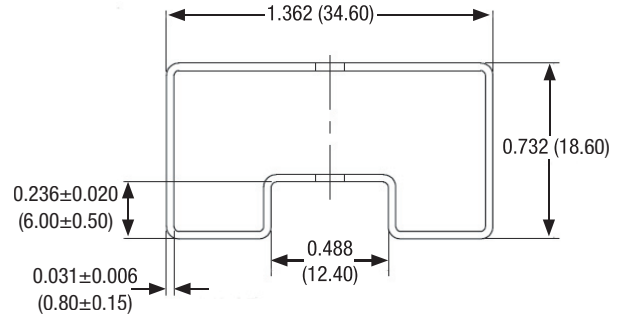

PACKAGING DETAILS

Order Code	Packaging	Qty
NDXXXXX	Tube	15