



APPLICATIONS

Wireless Network
Telecom/Datacom
Industry Control System
Measurement Equipment
Semiconductor Equipment

FEATURES

- 15 WATTS MAXIMUM OUTPUT POWER
- SINGLE OUTPUT UP TO 4A
- SMALL SIZE AND LOW PROFILE : 1.0 x 1.0 x 0.39 INCH
- HIGH EFFICIENCY UP TO 88%
- 4:1 ULTRA WIDE INPUT VOLTAGE RANGE
- SIX-SIDED CONTINUOUS SHIELD
- FIXED SWITCHING FREQUENCY
- INPUT TO OUTPUT ISOLATION
- INDUSTRY STANDARD PIN-OUT FEC15 SERIES COMPATIBLE
- CE MARK MEETS 2006/95/EC, 93/68/EEC AND 2004/108/EC
- UL60950-1, EN60950-1 AND IEC60950-1 LICENSED
- ISO9001 CERTIFIED MANUFACTURING FACILITIES
- COMPLIANT TO RoHS EU DIRECTIVE 2002/95/EC

OPTIONS

Positive logic Remote On/Off, Without trim, Without On/Off pin

DESCRIPTION

LCD15W DC/DC converters provide up to 15 watts of output power in an industry standard package and footprint. These units are specifically designed to meet the power needs of low profile. All models feature with 4:1 ultra wide input voltage of 9-36 VDC and 18-75VDC, comprehensively protected against over-current, over-voltage and input under-voltage protection conditions, and trimmable output voltage.

TECHNICAL SPECIFICATION All specifications are typical at nominal input, full load and 25°C otherwise noted

OUTPUT SPECIFICATIONS			
Output power			15 Watts
Voltage accuracy	Full load and nominal Vin		± 1%
Minimum load			0%
Voltage adjustability (Note 6)			±10%
Line regulation	LL to HL at Full Load	Single Dual	± 0.2% ± 0.5%
Load regulation	No Load to Full Load	Single Dual	± 0.2% ± 1.0%
Cross regulation (Dual)	Asymmetrical load 25% / 100% FL		± 5%
Ripple and noise	20MHz bandwidth (Measured with a 1µF M/C and a 10µF T/C)		See table
Temperature coefficient			±0.02% / °C, max.
Transient response recovery time	25% load step change		250µS
Over voltage protection	3.3V output		3.7V-5.4V
	5V output		5.6V-7.0V
	12V output		13.5V-19.6V
	15V output		16.8V-20.5V
Over load protection	% of FL at nominal input		150% typ.
Short circuit protection			Hiccup, automatics recovery
GENERAL SPECIFICATIONS			
Efficiency			See table
Isolation voltage	Input to Output		1600VDC, min.
	Input(Output) to Case		1000VDC, min.
Isolation resistance			10 ⁹ ohms, min.
Isolation capacitance			1000pF, max.
Switching frequency			400KHz, typ.
Approvals and standard			IEC60950-1, UL60950-1, EN60950-1
Case material			Nickel-coated copper
Base material			FR4 PCB
Potting material			Epoxy (UL94-V0)
Dimensions			1.0 X 1.0 X 0.39 Inch (25.4 X 25.4 X 9.9mm)
Weight			15g
MTBF (Note 1)	BELLCORE TR-NWT-000332		1.330x10 ⁶ hrs
	MIL-HDBK-217F		5.630x10 ⁵ hrs

INPUT SPECIFICATIONS			
Input voltage range	24V nominal input		9 – 36VDC
	48V nominal input		18 – 75VDC
Input surge voltage 100mS max.	24V input		50VDC
	48V input		100VDC
Input reflected ripple current	Nominal Vin and full load		30mA-p-p
Start up time	Nominal Vin and constant resistive load	Power up	30ms, max.
		Remote ON/OFF	30ms, max.
Start-up voltage	24V input		9VDC
	48V input		18VDC
Shutdown voltage	24V input		8VDC
	48V input		16VDC
Remote ON/OFF (Note 7)			
Positive logic(Optional)	DC-DC ON		Open or 3V < Vr < 15V
	DC-DC OFF		Short or 0V < Vr < 1.2V
Negative logic(Standard)	DC-DC ON		Short or 0V < Vr < 1.2V
	DC-DC OFF		Open or 3V < Vr < 15V
Input current of Remote control pin	Nominal Vin		-0.5mA~1.0mA
Remote off state input current	Nominal Vin		2.5mA
ENVIRONMENTAL SPECIFICATIONS			
Operating ambient temperature			-40°C to +85°C (with derating)
Maximum case temperature			105°C
Storage temperature range			-55°C ~ +125°C
Thermal impedance (Note 8)	Nature convection		18.2°C/Watt
	Nature convection with heat-sink		15.8°C/Watt
Thermal shock			MIL-STD-810F
Vibration			MIL-STD-810F
Relative humidity			5% to 95% RH
EMC CHARACTERISTICS			
EMI (Note 9)	EN55022		Class A
ESD	EN61000-4-2	Air Contact	± 8KV ± 6KV Perf. Criteria A
Radiated immunity	EN61000-4-3	10 V/m	Perf. Criteria A
Fast transient (Note 10)	EN61000-4-4	± 2KV	Perf. Criteria A
Surge (Note 10)	EN61000-4-5	± 1KV	Perf. Criteria A
Conducted immunity	EN61000-4-6	3 Vr.m.s	Perf. Criteria A



Model Number	Input Range	Output Voltage	Output Current		Output ⁽⁴⁾ Ripple & Noise	Input Current		Eff ⁽⁴⁾ (%)	Capacitor ⁽⁵⁾ Load max.
			Min. Load	Full Load		No Load ⁽³⁾	Full Load ⁽²⁾		
LCD15-24S3P3W	9 - 36 VDC	3.3 VDC	0mA	4000mA	75mVp-p	50mA	688mA	86	1000μF
LCD15-24S05W	9 - 36 VDC	5 VDC	0mA	3000mA	75mVp-p	70mA	762mA	86	1000μF
LCD15-24S12W	9 - 36 VDC	12 VDC	0mA	1300mA	100mVp-p	20mA	783mA	87	330μF
LCD15-24S15W	9 - 36 VDC	15 VDC	0mA	1000mA	100mVp-p	20mA	753mA	87	220μF
LCD15-24D05W	9 - 36 VDC	± 5 VDC	0mA	± 1500mA	100mVp-p	20mA	772mA	85	± 500μF
LCD15-24D12W	9 - 36 VDC	± 12 VDC	0mA	± 625mA	100mVp-p	25mA	753mA	87	± 150μF
LCD15-24D15W	9 - 36 VDC	± 15 VDC	0mA	± 500mA	100mVp-p	25mA	744mA	88	± 100μF
LCD15-48S3P3W	18 - 75 VDC	3.3 VDC	0mA	4000mA	75mVp-p	40mA	336mA	86	1000μF
LCD15-48S05W	18 - 75 VDC	5 VDC	0mA	3000mA	75mVp-p	40mA	382mA	86	1000μF
LCD15-48S12W	18 - 75 VDC	12 VDC	0mA	1300mA	100mVp-p	15mA	392mA	87	330μF
LCD15-48S15W	18 - 75 VDC	15 VDC	0mA	1000mA	100mVp-p	15mA	377mA	87	220μF
LCD15-48D05W	18 - 75 VDC	± 5 VDC	0mA	± 1500mA	100mVp-p	15mA	386mA	85	± 500μF
LCD15-48D12W	18 - 75 VDC	± 12 VDC	0mA	± 625mA	100mVp-p	15mA	382mA	86	± 150μF
LCD15-48D15W	18 - 75 VDC	± 15 VDC	0mA	± 500mA	100mVp-p	20mA	377mA	87	± 100μF

Note

- BELLCORE TR-NWT-000332. Case 1: 50% Stress, Temperature at 40°C.
MIL-HDBK-217F Notice2 @Ta=25 °C, Full load(Ground, Benign, controlled environment)
- Maximum value at nominal input voltage and full load.
- Typical value at nominal input voltage and no load.
- Typical value at nominal input voltage and full load.
- Test by minimum Vin and constant resistive load.
- Trimming allows the user to increase or decrease the output voltage set point of the module. This is accomplished by connecting an external resistor between the TRIM pin and either the +Vout pin or the -Vout pin.
- The ON/OFF control pin voltage is reference to -Vin.
The order number please see product standard table.
- Heat sink is optional and P/N:7G-0047C-F
- The LCD15W series can meet EN55022 Class A with parallel external capacitors to the input pins.
Recommend : 24Vin : 6.8μF/50V * 2 pcs 1812 MLCC
48Vin : 2.2μF/100V * 2 pcs 1812 MLCC
- An external input filter capacitor is required if the module has to meet EN61000-4-4, EN61000-4-5.
The filter capacitor Power Mate suggest: Nippon chemi-con KY series, 220 μF/100V, ESR 48mΩ.

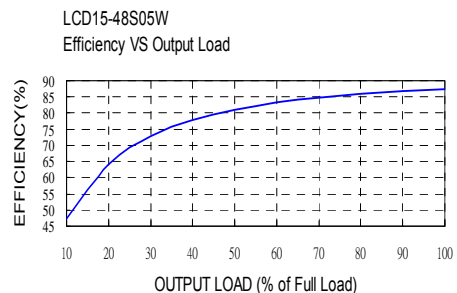
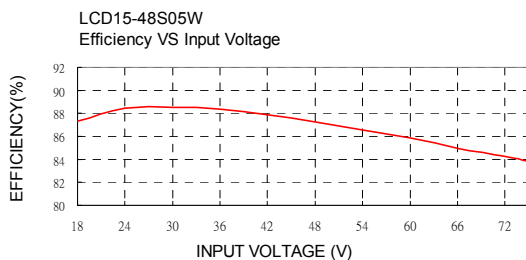
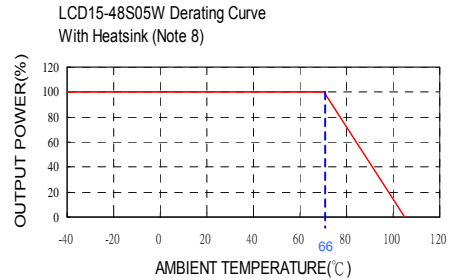
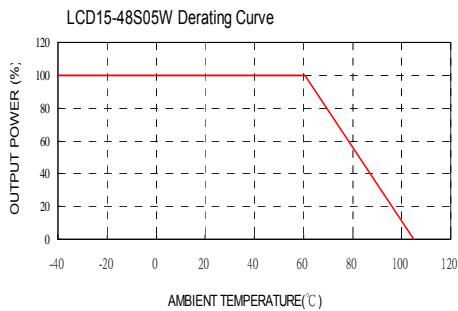

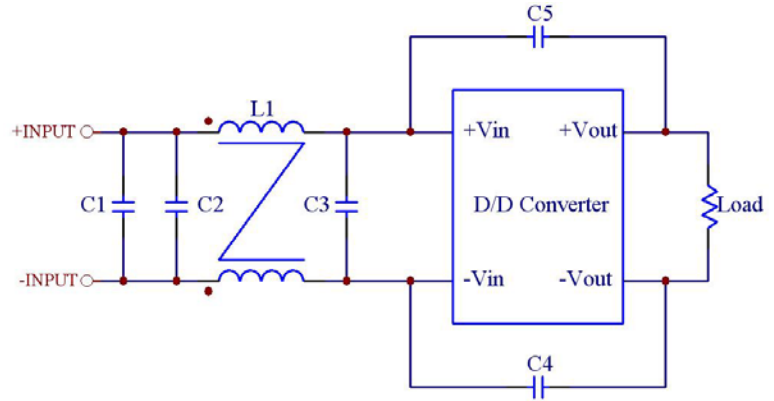
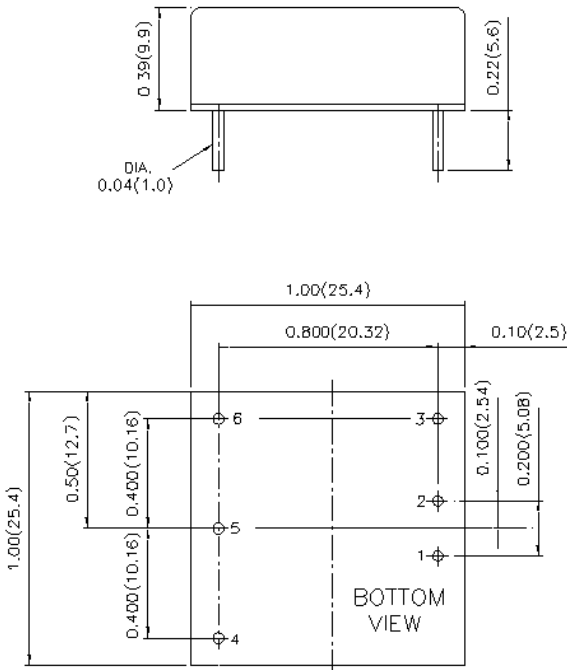

Recommended Filter for EN55022 Class B Compliance

The components used in the above figure, together with the manufacturers' part numbers for these components, are as follows:

	C1	C2	C3	C4 & C5	L1
LCD15-24xxxW	6.8μF/50V 1812 MLCC	N/A	6.8μF/50V 1812 MLCC	470pF/2KV 1808 MLCC	325μH Common Choke PMT-050
LCD15-48xxxW	2.2μF/100V 1812 MLCC	2.2μF/100V 1812 MLCC	2.2μF/100V 1812 MLCC	1000pF/2KV 1808 MLCC	325μH Common Choke PMT-050

- All dimensions in Inches (mm)
Tolerance: X.XX±0.02 (X.X±0.5)
X.XXX±0.01 (X.XX±0.25)
- Pin pitch tolerance ±0.01(0.25)
- Pin dimension tolerance ±0.004 (0.1)

PIN CONNECTION		
PIN	SINGLE	DUAL
1	+ INPUT	+ INPUT
2	- INPUT	- INPUT
3	ON/OFF	ON/OFF
4	+VOUT	+VOUT
5	TRIM	COMMON
6	-VOUT	-VOUT

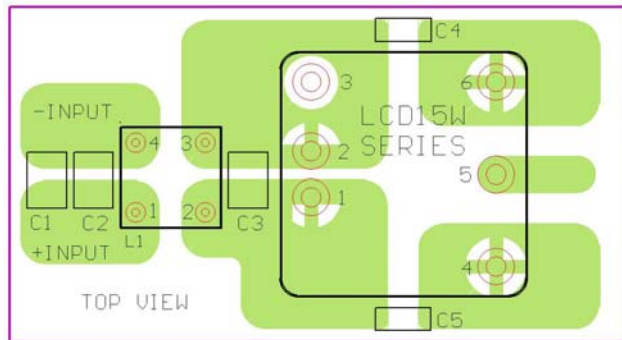

Recommended EN55022 Class B Filter Circuit Layout

EXTERNAL OUTPUT TRIMMING

Output can be externally trimmed by using the method shown below.

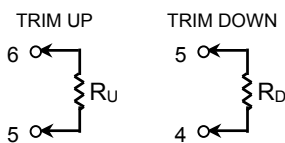

PRODUCT STANDARD TABLE

Option	Suffix
Negative remote ON/OFF(Standard)	
Positive remote ON/OFF without ON/OFF pin	-A
negative remote ON/OFF without TRIM pin without ON/OFF&TRIM pin	-B
	-C
	-D
positive remote ON/OFF without TRIM pin	-E